



■ Features :

- Protections: Short circuit / Overload / Over voltage
- Cooling by free air convection
- LED indicator for power on
- 100% full load burn-in test
- All using 105°C long life electrolytic capacitors
- Withstand 300VAC surge input for 5 second
- High operating temperature up to 70°C
- Withstand 5G vibration test
- High efficiency, long life and high reliability
- 3 years warranty



SPECIFICATION

| MODEL | | RT-125A | | | RT-125B | | | RT-125C | | | RT-125D | | |
|-----------------------|--|---|----------|----------------------------------|------------------|----------|----------|--|----------|----------|------------------|----------|----------|
| OUTPUT | OUTPUT NUMBER | CH1 | CH2 | CH3 | CH1 | CH2 | CH3 | CH1 | CH2 | CH3 | CH1 | CH2 | CH3 |
| | DC VOLTAGE | 5V | 12V | -5V | 5V | 12V | -12V | 5V | 15V | -15V | 5V | 24V | 12V |
| | RATED CURRENT | 12A | 5.5A | 1A | 12A | 5A | 1A | 10A | 4.5A | 1A | 8A | 3A | 2A |
| | CURRENT RANGE <small>Note.3</small> | 0 ~ 12A | 0 ~ 6A | 0 ~ 1A | 0 ~ 12A | 0 ~ 6A | 0 ~ 1A | 0 ~ 12A | 0 ~ 6A | 0 ~ 1A | 0 ~ 12A | 0 ~ 4A | 0 ~ 2A |
| | RATED POWER <small>Note.6</small> | 131W | | | 132W | | | 132.5W | | | 136W | | |
| | RIPPLE & NOISE (max.) <small>Note.2</small> | 80mVp-p | 120mVp-p | 80mVp-p | 80mVp-p | 120mVp-p | 120mVp-p | 80mVp-p | 150mVp-p | 150mVp-p | 80mVp-p | 150mVp-p | 120mVp-p |
| | VOLTAGE ADJ. RANGE | CH1: 4.75 ~ 5.5V | | | CH1: 4.75 ~ 5.5V | | | CH1: 4.75 ~ 5.5V | | | CH1: 4.75 ~ 5.5V | | |
| | VOLTAGE TOLERANCE <small>Note.3</small> | ±2.0% | +9,-5% | +6,-10% | ±2.0% | +9,-5% | ±6.0% | ±2.0% | +8,-5% | ±6.0% | ±2.0% | ±8.0% | ±6.0% |
| | LINE REGULATION <small>Note.4</small> | ±0.5% | ±1.0% | ±1.0% | ±0.5% | ±1.0% | ±1.0% | ±0.5% | ±1.0% | ±1.0% | ±0.5% | ±1.0% | ±1.0% |
| | LOAD REGULATION <small>Note.5</small> | ±1.0% | ±3.0% | ±6.0% | ±1.0% | ±3.0% | ±6.0% | ±1.0% | ±4.0% | ±6.0% | ±1.0% | ±5.0% | ±6.0% |
| SETUP, RISE TIME | 500ms, 20ms/230VAC | | | 1200ms, 30ms/115VAC at full load | | | | | | | | | |
| HOLD UP TIME (Typ.) | 25ms/230VAC | | | 30ms/115VAC at full load | | | | | | | | | |
| INPUT | VOLTAGE RANGE | 88 ~ 132VAC / 176 ~ 264VAC selected by switch | | | | | | 248 ~ 373VDC (Withstand 300VAC surge for 5sec. Without damage) | | | | | |
| | FREQUENCY RANGE | 47 ~ 63Hz | | | | | | | | | | | |
| | EFFICIENCY (Typ.) | 77% | | | 78% | | | 79% | | | 80% | | |
| | AC CURRENT (Typ.) | 3A/115VAC | | | 2A/230VAC | | | | | | | | |
| | INRUSH CURRENT (Typ.) | COLD START 50A/230VAC | | | | | | | | | | | |
| LEAKAGE CURRENT | <2mA / 240VAC | | | | | | | | | | | | |
| PROTECTION | OVERLOAD | 110 ~ 150% rated output power Protection type : Hiccup mode, recovers automatically after fault condition is removed | | | | | | | | | | | |
| | OVER VOLTAGE | CH1: 5.75 ~ 6.75V Protection type : Hiccup mode, recovers automatically after fault condition is removed | | | | | | | | | | | |
| ENVIRONMENT | WORKING TEMP. | -25 ~ +70°C (Refer to "Derating Curve") | | | | | | | | | | | |
| | WORKING HUMIDITY | 20 ~ 90% RH non-condensing | | | | | | | | | | | |
| | STORAGE TEMP., HUMIDITY | -40 ~ +85°C, 10 ~ 95% RH | | | | | | | | | | | |
| | TEMP. COEFFICIENT | ±0.03%/°C (0 ~ 50°C) on +5V output | | | | | | | | | | | |
| VIBRATION | 10 ~ 500Hz, 5G 10min./1cycle, period for 60min. each along X, Y, Z axes | | | | | | | | | | | | |
| SAFETY & EMC (Note 7) | SAFETY STANDARDS | UL62368-1, TUV EN62368-1, EAC TP TC 004 approved | | | | | | | | | | | |
| | WITHSTAND VOLTAGE | I/P-O/P:3KVAC I/P-FG:2KVAC O/P-FG:0.5KVAC | | | | | | | | | | | |
| | ISOLATION RESISTANCE | I/P-O/P, I/P-FG, O/P-FG:100M Ohms / 500VDC / 25°C / 70% RH | | | | | | | | | | | |
| | EMC EMISSION | Compliance to EN55032 (CISPR32) Class B, EN61000-3-2,-3, EAC TP TC 020 | | | | | | | | | | | |
| EMC IMMUNITY | Compliance to EN61000-4-2,3,4,5,6,8,11, EN61000-6-2 (EN50082-2), heavy industry level, criteria A, EAC TP TC 020 | | | | | | | | | | | | |
| OTHERS | MTBF | 209.3Khrs min. MIL-HDBK-217F (25°C) | | | | | | | | | | | |
| | DIMENSION | 199*98*38mm (L*W*H) | | | | | | | | | | | |
| | PACKING | 0.7Kg; 20pcs/14Kg/0.85CUFT | | | | | | | | | | | |
| NOTE | <ol style="list-style-type: none"> 1. All parameters NOT specially mentioned are measured at 230VAC input, rated load and 25°C of ambient temperature. 2. Ripple & noise are measured at 20MHz of bandwidth by using a 12" twisted pair-wire terminated with a 0.1uF & 47uF parallel capacitor. 3. Tolerance : includes set up tolerance, line regulation and load regulation. (In order to meet tolerance, it is recommended that CH1 load > 15% rated current for A, B,D type and CH1 load > 20% rated current for C type.) 4. Line regulation is measured from low line to high line at rated load. 5. Load regulation is measured from 20% to 100% rated load, and other output at 60% rated load. 6. Each output can work within current range. But total output power can't exceed rated output power. 7. The power supply is considered a component which will be installed into a final equipment. All the EMC tests are been executed by mounting the unit on a 360mm*360mm metal plate with 1mm of thickness. The final equipment must be re-confirmed that it still meets EMC directives. For guidance on how to perform these EMC tests, please refer to "EMI testing of component power supplies." (as available on http://www.meanwell.com) 8. Length of set up time is measured at cold first start. Turning ON/OFF the power supply very quickly may lead to increase of the set up time. 9. The ambient temperature derating of 3.5°C/1000m with fanless models and of 5°C/1000m with fan models for operating altitude higher than 2000m(6500ft). | | | | | | | | | | | | |

Mechanical Specification

Case No. 902A Unit:mm

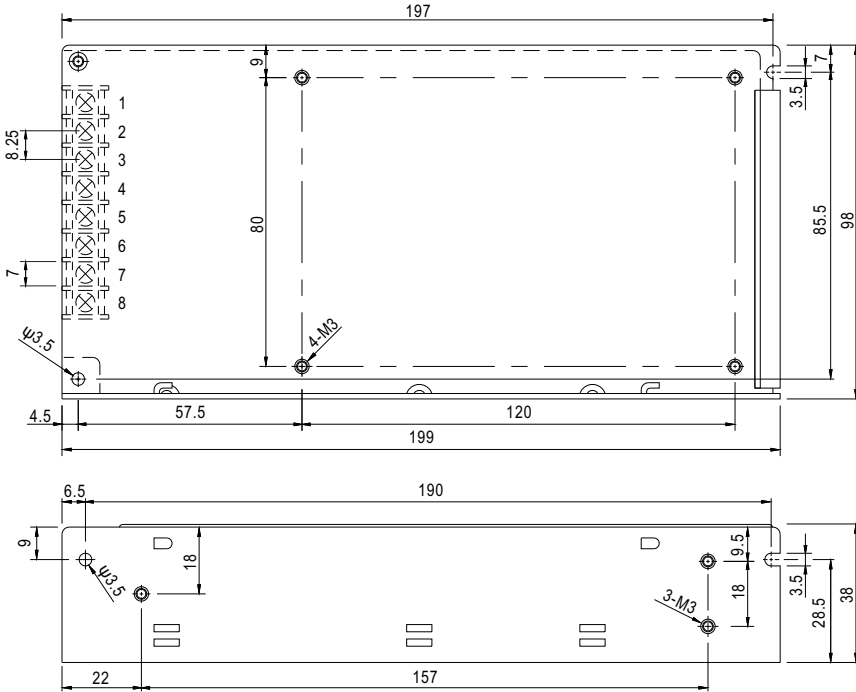

Terminal Pin No. Assignment

| Pin No. | Assignment | Pin No. | Assignment |
|---------|------------|---------|---------------|
| 1 | AC/L | 5 | DC OUTPUT V3 |
| 2 | AC/N | 6 | DC OUTPUT +V2 |
| 3 | FG \perp | 7 | DC OUTPUT COM |
| 4 | NC | 8 | DC OUTPUT +V1 |

Block Diagram

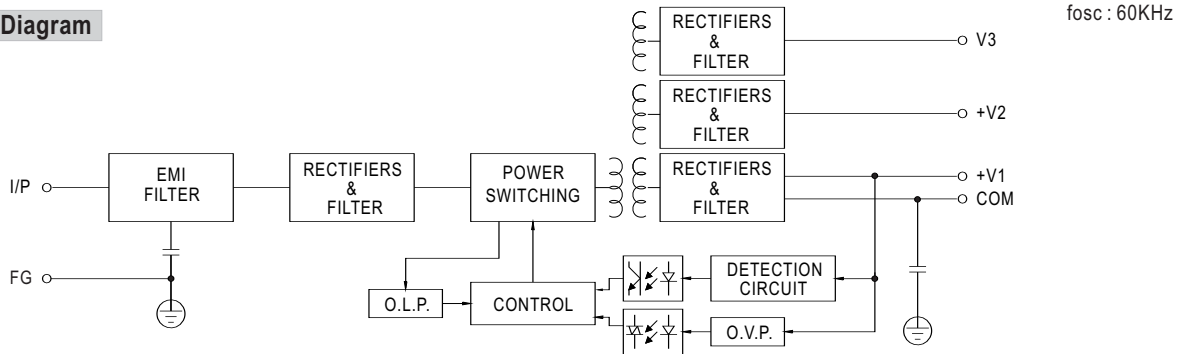

Derating Curve

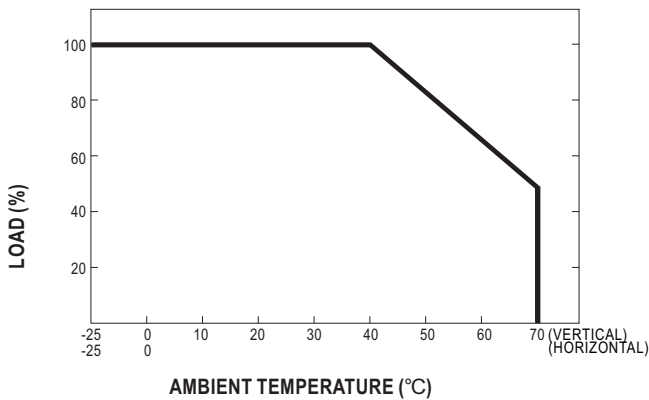

Static Characteristics

