

CONDUCTIVE POLYMER HYBRID ALUMINUM ELECTROLYTIC CAPACITORS

Upgrade
YH Chip type, High Temperature Series



- High temperature range, for 125°C use
- Complied to the RoHS directive

Item	Characteristics												
Operating temperature range	-55 ~ +125°C												
Leakage current max.	I = 0.01CV or 3μA whichever is greater (after 2 minutes)												
Capacitance tolerance	±20% at 120Hz, 20°C												
Dissipation factor max. (at 120Hz, 20°C)	<table border="1"> <tr> <td>WV</td> <td>16</td> <td>25</td> <td>35</td> <td>50</td> <td>63 ~ 100</td> </tr> <tr> <td>tanδ</td> <td>0.16</td> <td>0.14</td> <td>0.12</td> <td>0.10</td> <td>0.08</td> </tr> </table>	WV	16	25	35	50	63 ~ 100	tanδ	0.16	0.14	0.12	0.10	0.08
WV	16	25	35	50	63 ~ 100								
tanδ	0.16	0.14	0.12	0.10	0.08								
Low temperature characteristics (Impedance ratio at 100kHz)	$Z(-25^{\circ}\text{C}) / Z(+20^{\circ}\text{C}) \leq 1.5$ $Z(-55^{\circ}\text{C}) / Z(+20^{\circ}\text{C}) \leq 2.0$												
Load life	<p>After an application of DC bias voltage plus the rated AC ripple current for 4000 hours at 125°C. The measurement shall meet the following limits. The DC voltage plus the peak AC voltage combined must not exceed the rated voltage.</p> <table border="1"> <tr> <td>Capacitance change</td> <td>Within ±30% of initial value</td> </tr> <tr> <td>tanδ</td> <td>Less than 200% of the specified value</td> </tr> <tr> <td>ESR</td> <td>Less than 200% of the specified value</td> </tr> <tr> <td>Leakage current</td> <td>Less than specified value</td> </tr> </table>	Capacitance change	Within ±30% of initial value	tanδ	Less than 200% of the specified value	ESR	Less than 200% of the specified value	Leakage current	Less than specified value				
Capacitance change	Within ±30% of initial value												
tanδ	Less than 200% of the specified value												
ESR	Less than 200% of the specified value												
Leakage current	Less than specified value												
Shelf life (at 125°C)	After 1000 hours no load test, leakage current, capacitance and tanδ are same as load life value. The measurement shall be performed at 20°C by the KS C IEC 60384 - 4												
Resistance to soldering heat	<p>The following specifications shall be satisfied when the capacitors are restored to 20°C after exposing them at 250°C for 10 seconds.</p> <table border="1"> <tr> <td>Leakage current</td> <td>Less than specified value</td> </tr> <tr> <td>Capacitance change</td> <td>Within ±10% of initial value</td> </tr> <tr> <td>tanδ</td> <td>Less than specified value</td> </tr> </table>	Leakage current	Less than specified value	Capacitance change	Within ±10% of initial value	tanδ	Less than specified value						
Leakage current	Less than specified value												
Capacitance change	Within ±10% of initial value												
tanδ	Less than specified value												

● DRAWING

Unit : mm

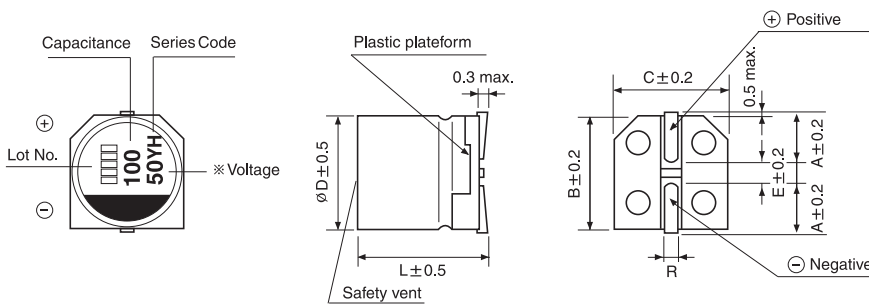

∅D×L	A	B	C	E	R
6.3×7.7	2.4	6.6	6.6	2.2	0.5~0.8
8×10	2.9	8.3	8.3	3.1	0.8~1.1
10×10	3.2	10.3	10.3	4.5	0.8~1.1
10×12.5	3.2	10.3	10.3	4.5	0.8~1.1

YH series

● DIMENSIONS & MAXIMUM PERMISSIBLE RIPPLE CURRENT

μF \diagdown WV	16			25			35		
47							6.3×7.7	35	1400
68				6.3×7.7	30	1400	6.3×7.7	35	1400
100				6.3×7.7	30	1400	8×10	27	1600
150	6.3×7.7	27	1450	8×10	27	1600	8×10	27	1600
							10×10	20	2000
220				8×10	27	1600			
270	8×10	22	1700	10×10	20	2000	10×10	20	2000
330				10×10	20	2000	10×12.5	17	2260
470	10×10	18	2100	10×12.5	16	2260			
560	10×12.5	14	2320						

μF \diagdown WV	50			63			80		
10				6.3×7.7	80	900			
15	6.3×7.7	40	1100						
22				6.3×7.7	80	900	8×10	45	1100
				8×10	40	1100			
33	6.3×7.7	40	1100	8×10	40	1100			
	8×10	30	1250	10×10	30	1400			
39							10×10	35	1200
47	8×10	30	1250				10×12.5	32	1400
56	10×10	25	1600	10×10	30	1400			
68	10×10	25	1600	10×12.5	22	1650			
100	10×10	25	1600						
150	10×12.5	19	1820						

μF \diagdown WV	100		
10	8×10	60	900
15	10×10	45	1120
18	10×12.5	40	1220

Ripple current (mA rms) at 125°C, 100kHz
 ESR (mΩ) at 20°C, 100kHz
 Case size $\varnothing D \times L$ (mm)

● FREQUENCY COEFFICIENT OF PERMISSIBLE RIPPLE CURRENT

Frequency	120Hz	1kHz	10kHz	100kHz
Coefficient	0.05	0.30	0.70	1.00